



DSG MANUAL

Digital Spectrogram Long-Term Acoustic Recorder



www.loggerheadinstruments.com
dmann@loggerheadinstruments.com
941-321-5437

Manual v1.6 (data format v 1006)
26 February 2010



Overview

Hardware

DSG is a low-power acoustic recorder designed to sample at rates up to 80 kHz continuously or on a duty cycle to Secure Digital High Capacity (SDHC) memory. The DSG also supports burst recording at sample rates up to 400 kHz. Data are saved in a DSG file format that can be downloaded to a PC for further analysis.

DSG recording is controlled by two script files on the SDHC card.

Default.txt controls overall recorder settings.

Sched.txt controls the scheduling of recording.

The DSG features power-saving features including sleep and wake cycles when performing interval recording.

Software

Two utilities are included on the installation disk and are also available on www.loggerheadinstruments.com. Double-click on DSGsetup_vxx.msi (where xx is the version number) to install.

DSGSchedule can be used to create the Default.txt and Sched.txt script files. These files could also be created by hand.

DSG2wav is a utility that converts DSG files to wav files.



DSGSchedule Software

DSGSchedule Software Description

DSGSchedule is used to create the configuration (*Default.txt*) and schedule (*Sched.txt*) files for DSG.

Default.txt contains the DSG recorder configuration (sample rate, sleep mode, date and time setting).

Sched.txt contains a list of dates and times of recordings.

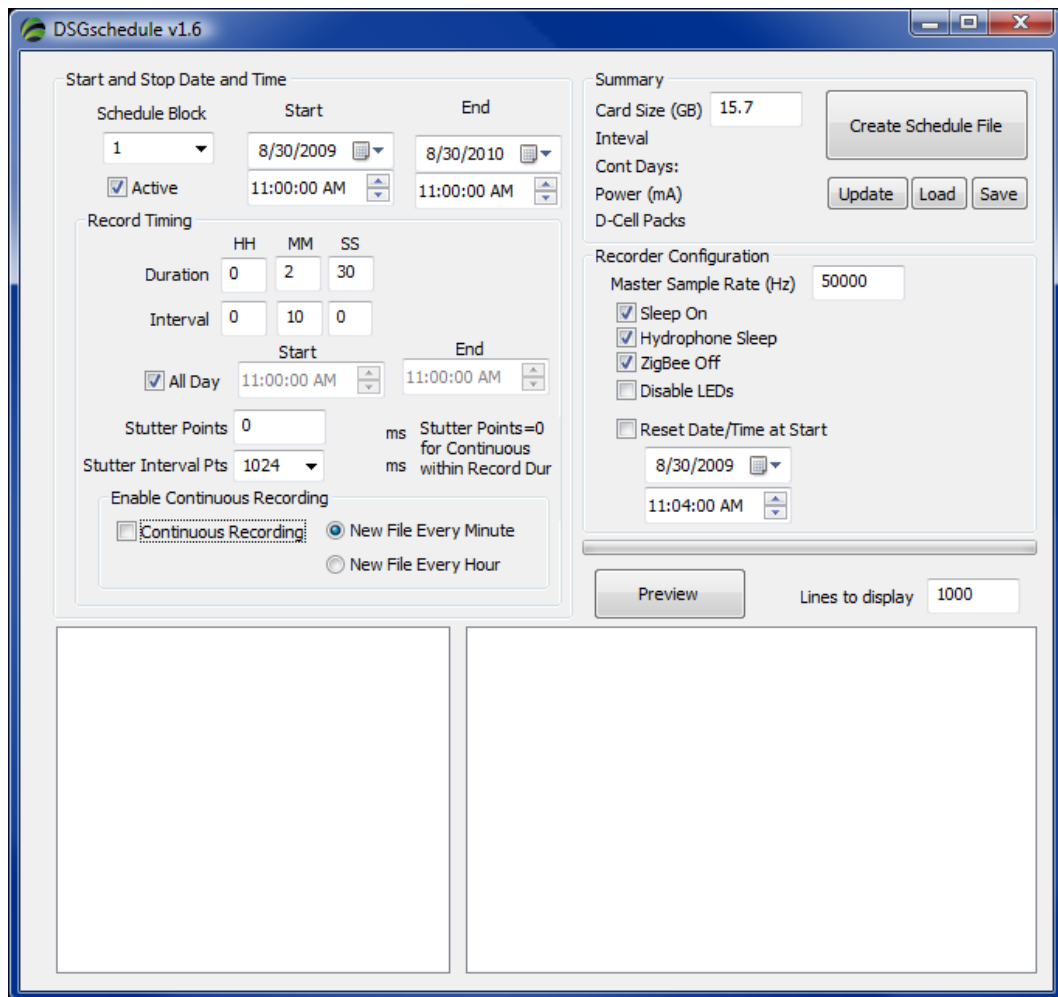

The screenshot shows the DSGSchedule v1.6 software interface. The window title is "DSGSchedule v1.6". The interface is divided into several sections:

- Start and Stop Date and Time:**
 - Schedule Block: 1
 - Start: 8/30/2009 11:00:00 AM
 - End: 8/30/2010 11:00:00 AM
 - Active
- Record Timing:**
 - Duration: 0 HH, 2 MM, 30 SS
 - Interval: 0, 10, 0
 - All Day
 - Start: 11:00:00 AM
 - End: 11:00:00 AM
 - Stutter Points: 0 ms
 - Stutter Interval Pts: 1024
 - Stutter Points=0 for Continuous within Record Dur
 - Enable Continuous Recording:
 - Continuous Recording
 - New File Every Minute
 - New File Every Hour
- Summary:**
 - Card Size (GB): 15.7
 - Interval:
 - Cont Days:
 - Power (mA):
 - D-Cell Packs:
 - Buttons: Update, Load, Save
 - Button: Create Schedule File
- Recorder Configuration:**
 - Master Sample Rate (Hz): 50000
 - Sleep On
 - Hydrophone Sleep
 - ZigBee Off
 - Disable LEDs
 - Reset Date/Time at Start
 - Start: 8/30/2009
 - Time: 11:04:00 AM
- Preview:**
 - Preview button
 - Lines to display: 1000

Summary

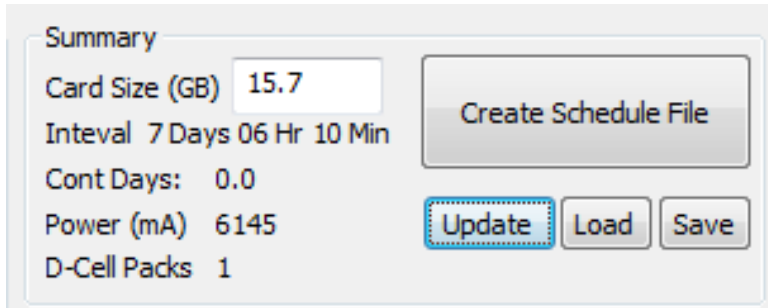

Summary

Card Size (GB) 15.7

Interval 7 Days 06 Hr 10 Min

Cont Days: 0.0

Power (mA) 6145

D-Cell Packs 1

Create Schedule File

Update Load Save

Summary information is useful for developing recording schedules that optimize use of card space and battery power.

Click the **Update** button to calculate the Summary information. This will also show the entire default.txt and sched.txt files that would be created below. This can take a long time if the schedule is long.

Card Size (GB): Enter the Secure Digital card size in Gigabytes. Note that manufacturers are generous in how they describe card size. 16 GB cards are often smaller than 16 GB (e.g. 15.7 GB). This can be checked by examining the Properties of the card in Windows.

Interval: Estimate of the amount of time it will take to fill the memory of the card based on the schedule interval settings.

Cont Days: If continuous recording is enabled, will indicate number of days of continuous recording. Total record time is Interval + Cont Days.

Power (mA): Estimated power requirements until the SD card is filled.

D-Cell Packs: Estimated number of 3-D-cell packs needed for the power requirements. This estimate is made assuming D-cells provide 12 Ah.

Update Button: Updates calculation of summary data.

Save Button: Saves DSGSchedule settings to a file (.sch). Useful for creating preset schedules that will be loaded multiple times.

Load Button: Loads DSGSchedule settings file (.sch).

Create Schedule File Button: Creates schedule files (Default.txt and Sched.txt) on Secure Digital card. Simply select the root directory of the SD card and the files will be created in a folder named Script. This operation could take minutes for long schedule files. Note, this operation does not update the Summary information.

Recorder Configuration

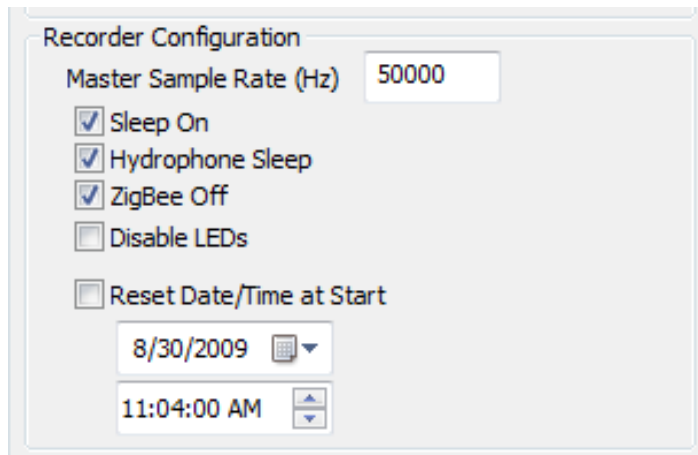

The screenshot shows a 'Recorder Configuration' dialog box with the following settings:

- Master Sample Rate (Hz): 50000
- Sleep On
- Hydrophone Sleep
- ZigBee Off
- Disable LEDs
- Reset Date/Time at Start

Below the checkboxes, there are two input fields: a date field set to '8/30/2009' and a time field set to '11:04:00 AM'.

The Recorder Configuration is used to configure the settings in the *Default.txt* file.

Master Sample Rate (Hz): Sample rate of DSG in Hz (samples/second). The DSG has a built-in low-pass filter at 40 kHz. The DSG requires an integer sample period in microseconds. The sample rate will be automatically adjusted to result in an integer sample period

Sleep On: When checked, DSG will sleep in between recording sessions. This saves power. DSG draws about 110 mA while running and 1-2 mA while sleeping.

Hydrophone Sleep: If checked, power to the hydrophone will sleep when the DSG sleeps. Only uncheck if you need to use the power to the hydrophone while the DSG is sleeping.

ZigBee Off: Turns off ZigBee communications at start to save power.

Disable LEDs: If checked, will disable LEDs after first recording. Disabling LEDs does not save much power, it is intended for situations where blinking LEDs would be problematic (such as deployments on animals).

Reset Date/Time at Start: When checked, the DSG will reset the internal real-time clock to the date and time specified in the drop-down boxes when power is applied to the DSG (and whenever the DSG is restarted). See section on Setting Date and Time. When this box is unchecked, the DSG will use the time on the internal clock.

Start and Stop Date and Time

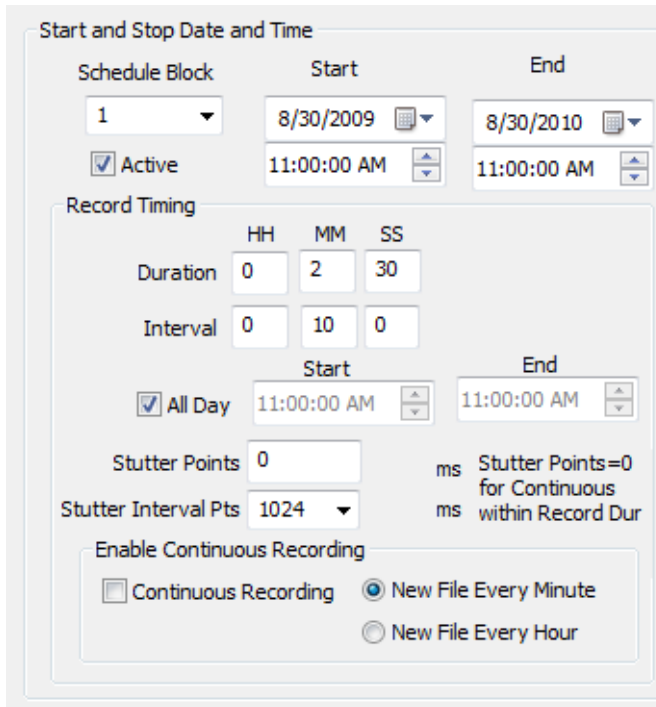

This configures the time and duration of recordings using schedule blocks. Each block can have its own timing configuration. The blocks are then combined to produce one *Sched.txt* file that is used by DSG.

Schedule Block: Select schedule blocks with the drop-down box. 10 Schedule Blocks are available. Check the Active box to make the schedule block active (i.e. the timing settings from active schedule blocks are used to make the *Sched.txt* file). By default only Schedule Block 1 is active.

Start/End: Used to set the overall start date and time and end date and time of the recordings for a given schedule block. Each schedule block can have its own start and end dates and times.

Record Timing

The record timing is used to set the duration and period of recordings. One file is created for each interval.

Duration: Duration of recording in hours (HH), minutes (MM), and seconds (SS).

Interval: Interval between start times of recordings in hours (HH), minutes (MM), and seconds (SS). The interval must be longer than the duration. This is NOT the time between the end of one file and the beginning of the next file.



All Day/Start/End: If the All Day box is checked, recordings will be made throughout each day at the specified interval. If the All Day box is not checked, recordings will only be made for the part of the day specified by the Start and End times. This allows recordings to be made for just part of the day, such as at dawn.

Stutter Recording is used to record small time slices within a longer record duration. Stutter recording is a form of lossy data compression.

Stutter Points: Number of points to save. Must be less than the stutter interval. If Stutter Points is set to 0, the recording will be continuous for the record duration.

Stutter Interval Pts: Interval between start of stutter recordings.

Continuous Recording: If checked, files will be recorded continuously starting at the date and time indicated by the Start calendar drop-down. Once continuous recording is encountered in a schedule file, no other recording schedules will be processed.

New File Every Minute: In Continuous Record mode, this will make a new file every minute.

New File Every Hour: In Continuous Record mode, this will make a new file every hour.

After configuring the Schedule Setup, click the Update button to determine file storage requirements.

Tip

The number of combinations of settings is infinite. It is highly recommended that a bench top test of the recording settings be made prior to deployment.

File Preview

Click on the Preview Button to inspect what will be generated in the schedule file. The left panel shows what will be in *default.txt* and the right panel shows what will be in *sched.txt*.

Inspect the timing to make sure that it will produce the schedule you desire.

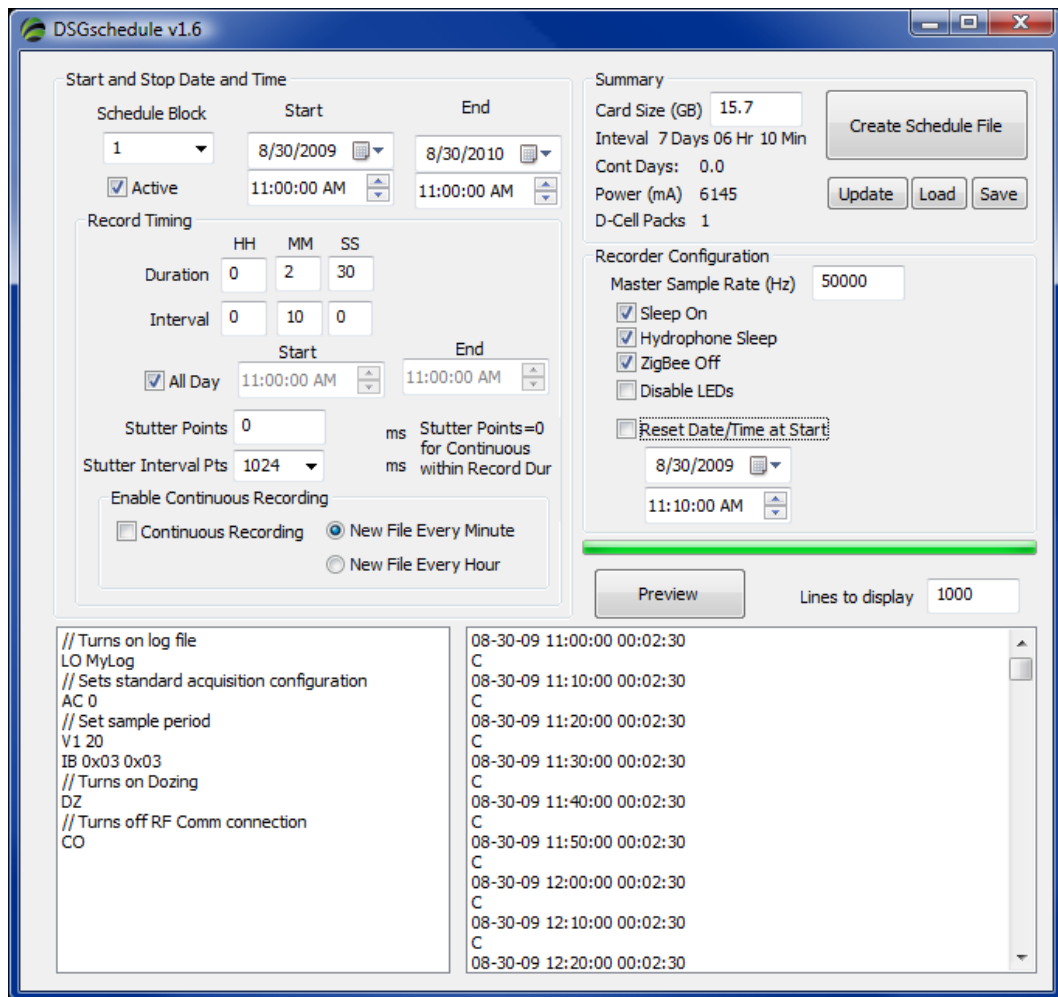

The screenshot shows the DSGschedule v1.6 software interface. The window is titled "DSGschedule v1.6" and contains several configuration panels:

- Start and Stop Date and Time:**
 - Schedule Block: 1
 - Start: 8/30/2009 11:00:00 AM
 - End: 8/30/2010 11:00:00 AM
 - Active
- Record Timing:**
 - Duration: 0 HH, 2 MM, 30 SS
 - Interval: 0, 10, 0
 - All Day
 - Start: 11:00:00 AM, End: 11:00:00 AM
 - Stutter Points: 0 ms
 - Stutter Interval Pts: 1024 ms
 - Stutter Points=0 for Continuous within Record Dur
 - Enable Continuous Recording:
 - Continuous Recording
 - New File Every Minute
 - New File Every Hour
- Summary:**
 - Card Size (GB): 15.7
 - Interval: 7 Days 06 Hr 10 Min
 - Cont Days: 0.0
 - Power (mA): 6145
 - D-Cell Packs: 1
 - Buttons: Create Schedule File, Update, Load, Save
- Recorder Configuration:**
 - Master Sample Rate (Hz): 50000
 - Sleep On
 - Hydrophone Sleep
 - ZigBee Off
 - Disable LEDs
 - Reset Date/Time at Start:
 - Date: 8/30/2009
 - Time: 11:10:00 AM
- Preview:**
 - Buttons: Preview, Lines to display: 1000
 - Left panel (default.txt):

```
// Turns on log file
LO MyLog
// Sets standard acquisition configuration
AC 0
// Set sample period
V1 20
IB 0x03 0x03
// Turns on Dozing
DZ
// Turns off RF Comm connection
CO
```
 - Right panel (sched.txt):

```
08-30-09 11:00:00 00:02:30
C
08-30-09 11:10:00 00:02:30
C
08-30-09 11:20:00 00:02:30
C
08-30-09 11:30:00 00:02:30
C
08-30-09 11:40:00 00:02:30
C
08-30-09 11:50:00 00:02:30
C
08-30-09 12:00:00 00:02:30
C
08-30-09 12:10:00 00:02:30
C
08-30-09 12:20:00 00:02:30
```

Setting the Date and Time

DSG has an internal real-time clock that is powered by a Lithium coin cell (CR2032) so that it maintains the proper time, even when the main power is turned off. The date and time on DSG are set using the Default.txt file on the SD card.

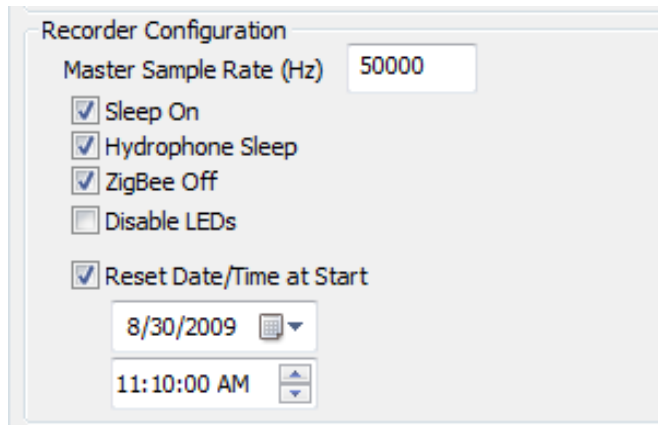

1. Program the SD card.
 - a. In DSGschedule check Reset Date/Time at Start.
 - b. Select the date and time that you will start the DSG. Remember to give yourself time to eject the SD card from the computer and insert it into the DSG.
2. Insert SD card into DSG SD card slot.
3. Switch on DSG when it is the time you had entered in DSGschedule.

After setting the date and time, the DSG will retain the current date and time.

Future schedule files should be created without resetting the date and time.

Note that it is possible to reset the date and time and just let the DSG run. The downside of this is that if the DSG accidentally restarted (e.g. if the batteries became disconnected and then reconnected), the time would be reset to the time indicated in the *Default.txt* file on the card.

Daylight Saving Time

There is no Daylight Saving Time on the DSG real-time clock.



Schedule Files

Schedule files are text files in the Script directory on the SD card that specify the start date and time and record duration. Every other line contains a code indicating whether the recording is continuous (C) or stutter (S).

<u>Record Start Date & Time</u>	<u>Duration</u>
MM-DD-YY HH:MM:SS	HH:MM:SS

Example Sched.txt file

```
05-06-08 19:00:00 00:02:30
C
05-06-08 19:10:00 00:02:30
C
05-06-08 19:20:00 00:02:30
C
05-06-08 19:30:00 00:02:30
C
05-06-08 19:40:00 00:02:30
C
05-06-08 19:50:00 00:02:30
C
```

Example Schedule Files

The following presents several scenarios for constructing schedule files. It is important to examine the schedule files prior to deployment to make sure they do what you want. Schedule files can also be created manually if recording schedules are required which can not be produced with DSGschedule.

Scenario 1: Record 10 seconds every 10 minutes at 50,000 Hz sample rate. This can be created with 1 Schedule Block.

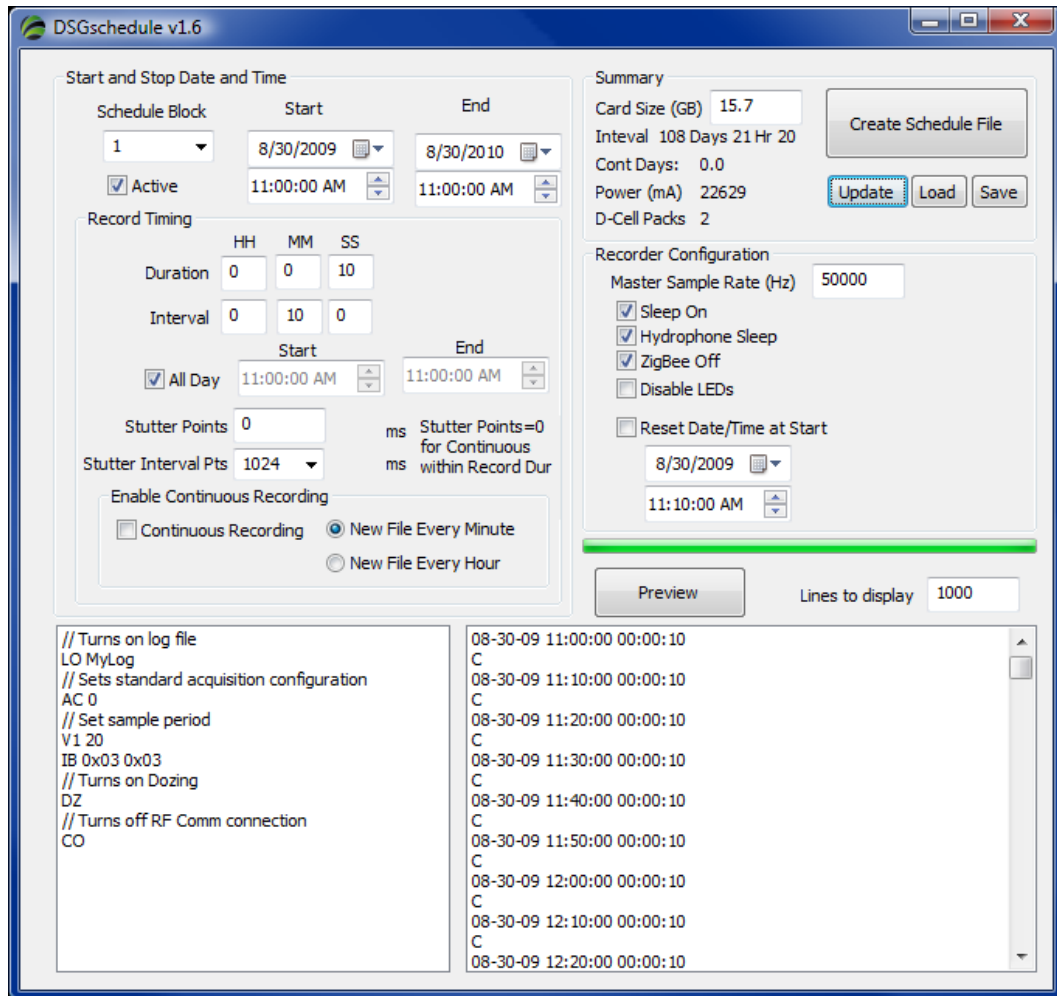

The screenshot shows the DSGschedule v1.6 software interface. The 'Start and Stop Date and Time' section is configured with Schedule Block 1, Start date 8/30/2009 at 11:00:00 AM, and End date 8/30/2010 at 11:00:00 AM. The 'Record Timing' section shows a Duration of 00:10:00 and an Interval of 00:10:00. The 'Recorder Configuration' section shows a Master Sample Rate of 50000 Hz and various options checked, including Sleep On, Hydrophone Sleep, and ZigBee Off. The 'Summary' section shows Card Size (GB) 15.7, Interval 108 Days 21 Hr 20, Cont Days: 0.0, Power (mA) 22629, and D-Cell Packs 2. The 'Enable Continuous Recording' section has 'New File Every Minute' selected. The 'Preview' section shows a list of recording events: 08-30-09 11:00:00 00:00:10 C, 08-30-09 11:10:00 00:00:10 C, 08-30-09 11:20:00 00:00:10 C, 08-30-09 11:30:00 00:00:10 C, 08-30-09 11:40:00 00:00:10 C, 08-30-09 11:50:00 00:00:10 C, 08-30-09 12:00:00 00:00:10 C, 08-30-09 12:10:00 00:00:10 C, and 08-30-09 12:20:00 00:00:10 C. The 'Lines to display' is set to 1000.

Note that the End date is beyond when the SD card will fill. By default DSGschedule sets the End date to be 1 year after the current date. In this case the DSG will run until its card is filled.

Scenario 2: This scenario will record more intensively at dawn than during the rest of the day. Record 10 seconds every 10 minutes at 50,000 Hz sample rate all day, and record for 1 minute every 5 minutes from 06:00 AM to 07:00 AM. This can be created with 2 Schedule Blocks.

Schedule Block 1

Start: 7:10:00 AM

End: 5:50:00 AM

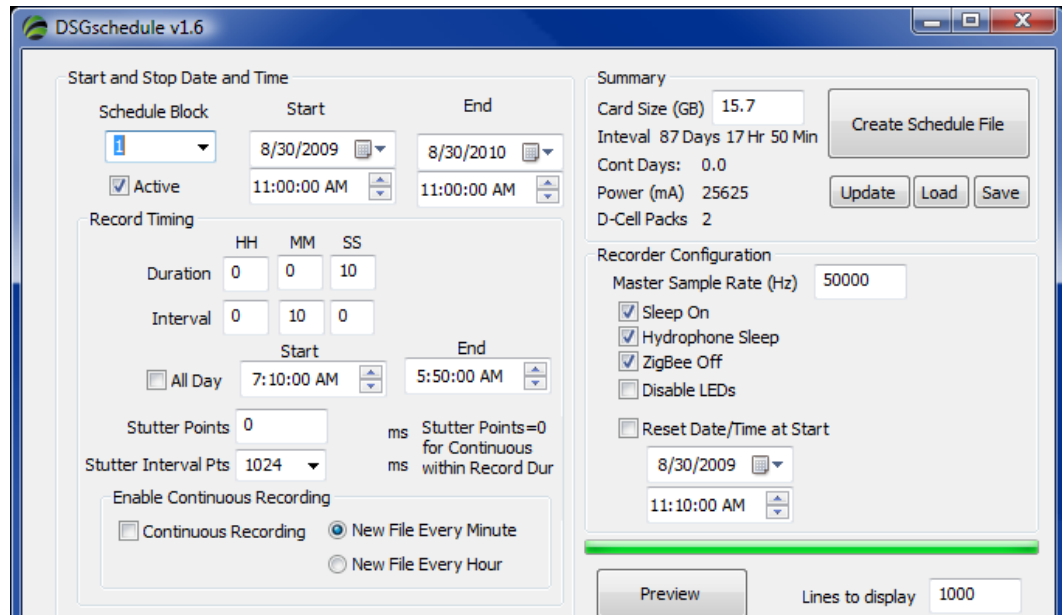

Schedule Block 2

Start: 6:00:00 AM

End: 7:00:00 AM

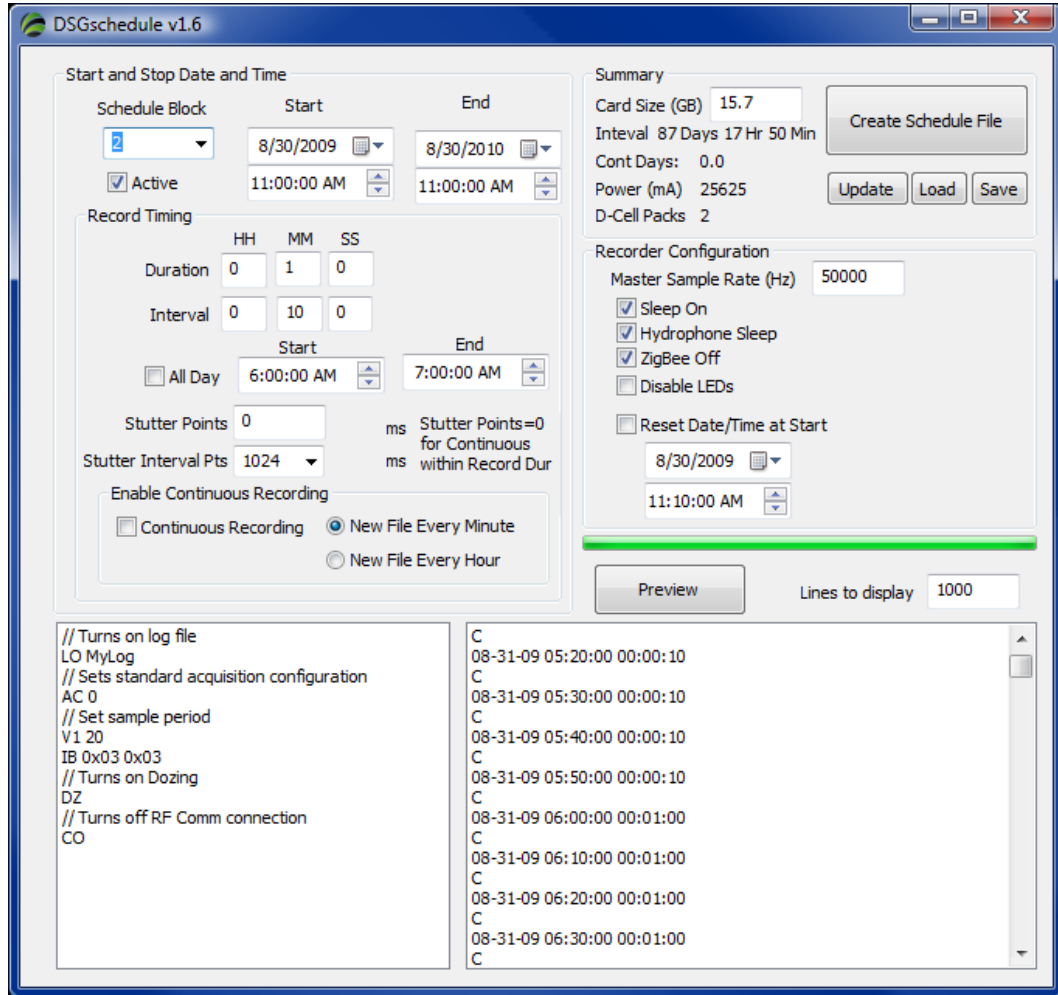

Tip—Overlapping Schedule Blocks
 If Schedule Blocks overlap the DSG will follow the settings for the first line, and ignore the following record times which are overlapped.

Scenario 3: This scenario will use stutter record at a high sample rate, which might be used to detect ultrasonic signals. Record 1 minute every 10 minutes at 200,000 Hz sample rate all day. The data will be saved in stuttered format with 410 points saved every 4096 points.

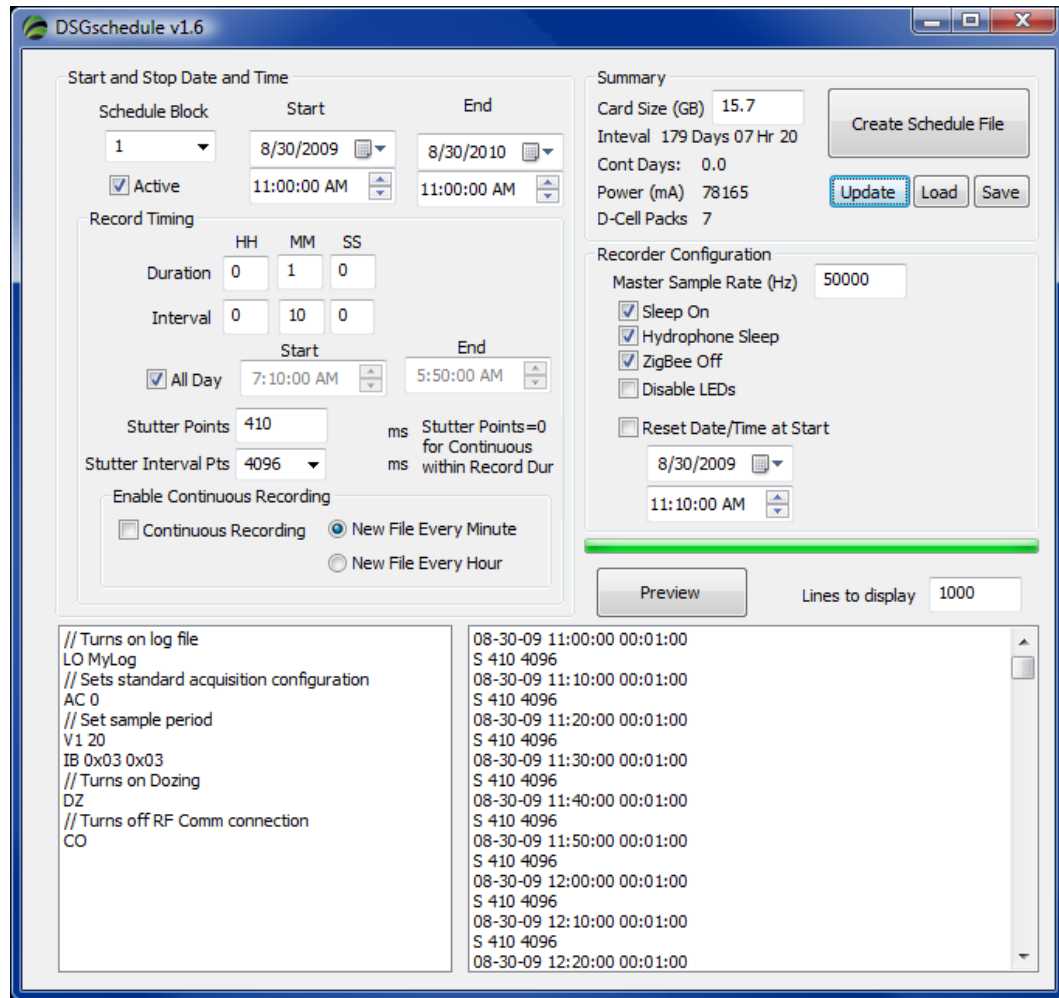

Tip—Initial record

If you are starting the DSG with a long delay, it is useful to create a line in the schedule file that makes a short recording at the start of the session to verify that the DSG is working. This can be done with a separate Schedule Block. When DSG goes into sleep mode, no LEDs are illuminated.

Scenario 4: Continuous Recording. This scenario will use an interval recording for 1 day and then switch to continuous recording.

Block 1: Record 1 minute every 10 minutes at 50,000 Hz sample rate all day from 1 Sept 2009 through 2 Sept 2009.

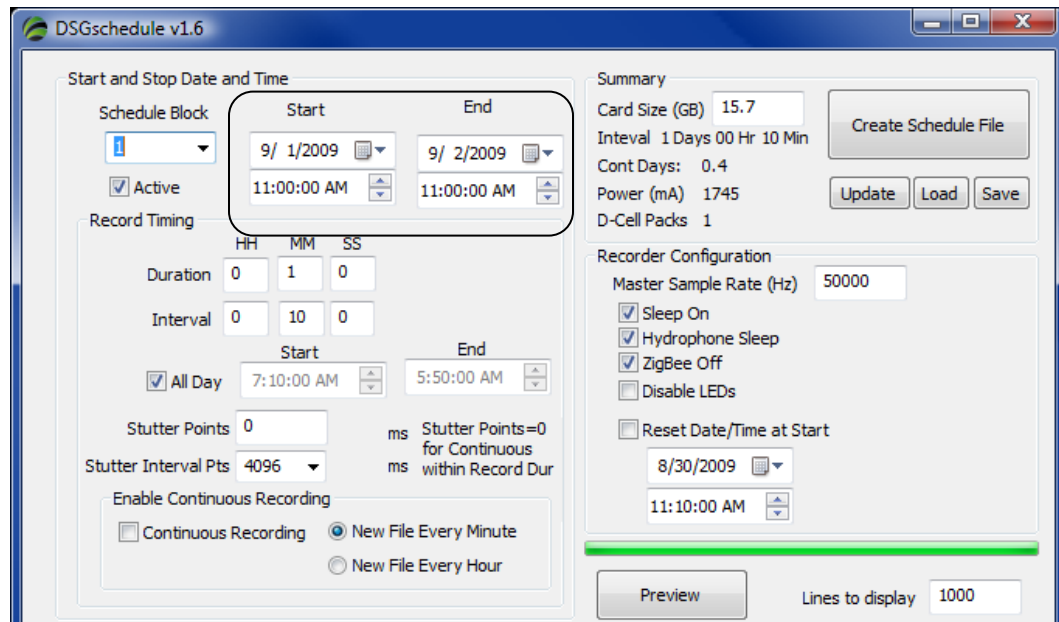

Block 2: Continuous recording starting on 2 Sept 2009 at 11:10:00 AM. Note that this time does not coincide with a time from the first block. This is very important. If the continuous recording was started on 2 Sept 2009 at 11:00:00 AM, it would never be run, because there was an entry at that time from Block 1. Note that CC is the code for a continuous recording.

The Summary data indicates that you will have interval recording for 1 day and continuous recording for 0.4 days.

DSGschedule v1.6

Start and Stop Date and Time

Schedule Block: 2 Start: 9/ 2/2009 End: 9/ 5/2009

Active Start: 11:10:00 AM End: 11:00:00 AM

Record Timing

Duration: HH:MM:SS 0:1:0

Interval: 0:10:0

All Day Start: 6:00:00 AM End: 7:00:00 AM

Stutter Points: 0 ms Stutter Points=0 for Continuous within Record Dur

Stutter Interval Pts: 1024 ms

Enable Continuous Recording

Continuous Recording New File Every Minute New File Every Hour

Summary

Card Size (GB) 15.7 Interval 1 Days 00 Hr 10 Min Cont Days: 0.4 Power (mA) 1745 D-Cell Packs 1

Recorder Configuration

Master Sample Rate (Hz) 200000

Sleep On Hydrophone Sleep ZigBee Off Disable LEDs Reset Date/Time at Start

8/30/2009 11:10:00 AM

Lines to display 1000

```
// Turns on log file
LO MyLog
// Sets standard acquisition configuration
AC 0
// Set sample period
V1 5
IB 0x03 0x03
// Turns on Dozing
DZ
// Turns off RF Comm connection
CO
//Continuous Record New File Every Minute
FM 4
```

```
09-02-09 10:00:00 00:01:00
C
09-02-09 10:10:00 00:01:00
C
09-02-09 10:20:00 00:01:00
C
09-02-09 10:30:00 00:01:00
C
09-02-09 10:40:00 00:01:00
C
09-02-09 10:50:00 00:01:00
C
09-02-09 11:00:00 00:01:00
C
09-02-09 11:10:00 00:01:00
CC
```



LED Indicators

There are two LEDs, one on the edge (LED1) and on towards the middle of the board (LED2).

Normal Operation

Startup: When power is applied LED2 will turn Green for 2-45 seconds as the code is loaded and the memory card verified.

Record Mode: Both LED1 and LED2 will flash green during recording. If LED1 goes red, the DSG is not able to transfer data to the SD card fast enough for the recording configuration. This will happen at sample rates higher than 80 kHz.

Sleep Mode On: In Sleep mode, no LEDs are on.

Sleep Mode Off: LED1 will blink green in between recording intervals.

Error Modes

LED2--blinking red at start; Clock is not set properly (time detected on clock is before year 2008).

LED1 and LED2—both blinking red at start; no SD card detected

LED1: Solid red at start means unable to write to real-time clock. Remove power and try again.



Data

Data are saved as 16-bit .dsg files onto the Secure Digital card. The .dsg file format is described in the appendix. It consists of data blocks containing time stamps and blocks of 16-bit data. These files can be converted to wav files using the DSG2wav utility.

File Names

File names are created automatically and incremented starting at 1 and end with the file extension .dsg.

Stopping DSG

Wait to turn off power to DSG until recording of a file has ended to avoid corrupting a data file. After power is off, remove the SD card by pulling it out. Newer versions of the DSG board have the spring eject disabled to prevent accidental ejection.

Downloading Files

Files can be downloaded to a PC through an SDHC interface or the supplied USB SDHC drive. Note that SDHC cards may not be able to be read by older SD card readers that do not support SDHC cards.

Log Files

A log file (*MyLog.txt*) is created on the SD card in the Log directory that is used to store information on when the DSG was started and when each recording was made.



Example MyLog.txt

```
System      | 05-07-08 09:01:06 | Log Opened *****  
System      | 05-07-08 09:01:06 | Session Started  
System      | 05-07-08 09:10:00 | Record Begin  
Test        | 05-07-08 09:12:31 | Data 1842  3316  
System      | 05-07-08 09:12:31 | Record End  
System      | 05-07-08 09:20:00 | Record Begin  
Test        | 05-07-08 09:22:31 | Data 1845  3212  
System      | 05-07-08 09:22:31 | Record End
```



DSG2wav

DSG2wav will convert *.dsg* to *.wav* files. This process removes the *dsg* header and timing information from the files to create the *.wav* files.

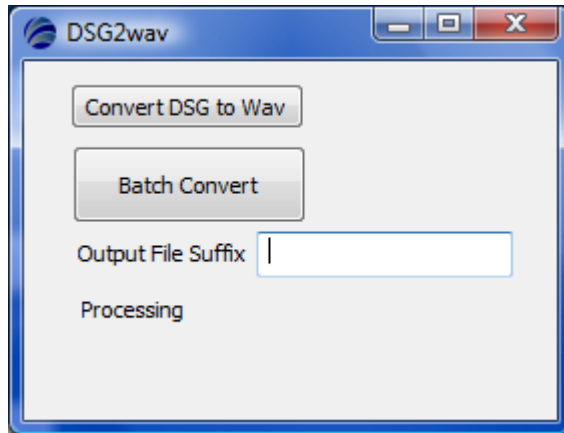

Convert DSG to Wav: Converts one file at a time allowing user to save the *wav* file to any destination.

Batch Convert: Converts entire folder of *.dsg* files to *.wav* files. The new files will be placed inside a subdirectory named *wav*. File names are derived from the *.dsg* file names with an optional suffix attached.

Output File Suffix: Optional text that will be added to the *.wav* file names.

Setting up DSG in Underwater Housing

Step 1. Prepare SDHC card. Program SDHC card with DSGschedule. Be sure to safely eject card before removing from computer. Insert SDHC card into DSG. The SDHC card is removed by pressing in on it to spring it out.

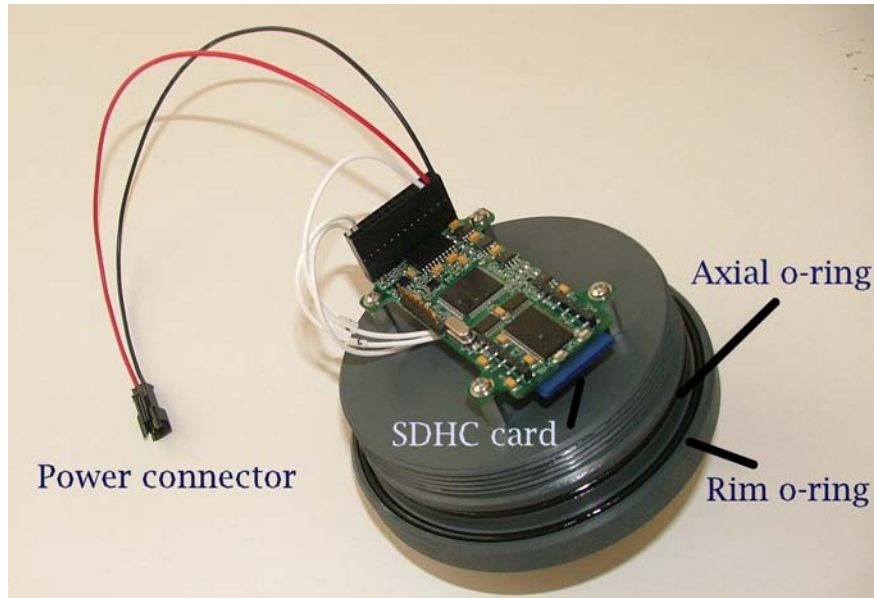

Step 2. O-rings. Clean and grease o-rings with silicone grease, and insert into the groove on the lid. There are two o-rings in each lid. The o-ring (size-155) on the rim is larger than the axial o-ring (size-153).

The o-rings need to be removed and cleaned for each use. If there are nicks in an o-ring do not use it. If you need more o-rings, contact Loggerhead Instruments.

Step 3. Install batteries.

IMPORTANT: In double battery pack, the batteries are oriented in opposite directions. The negative (-) flat side of the battery is positioned against the spring.

Batteries should be taped into holder to prevent them from falling out.

Either D-cells or rechargeable batteries may be used.
Note that battery life estimates in DSGschedule are for alkaline D-Cells.
Rechargeable batteries typically have less power.

Slide battery pack into housing as it lies on its side.

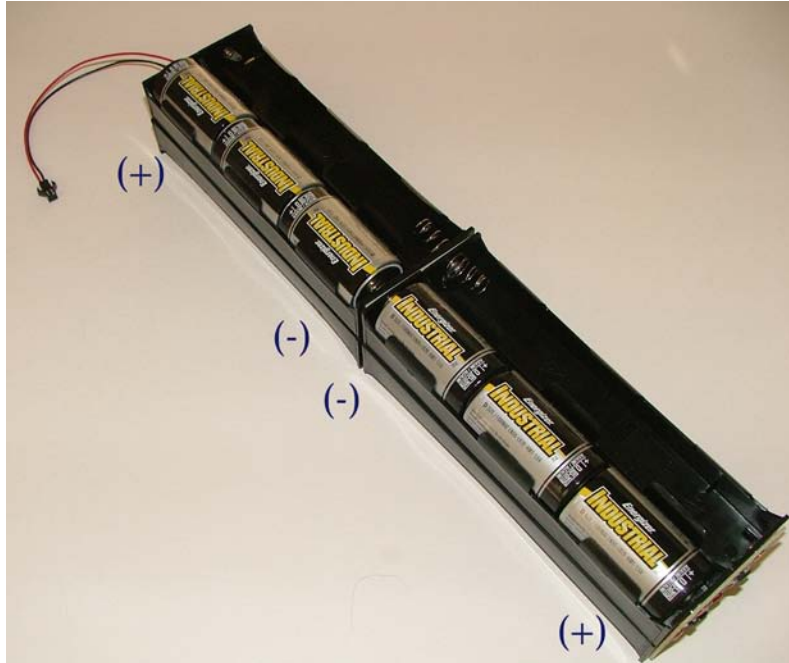

Note that the negative (flat) side of the batteries should be oriented towards the spring in the battery holder. This picture shows two of the eight 3-cell battery packs full. Note each battery pack is connected in parallel, so only one battery pack is required to power the DSG. DSGschedule will indicate the estimated number of alkaline battery packs required for a deployment based on the recording settings.

Step 4. Connect DSG battery connector to battery pack.

Connect to power connector on the DSG.

Verify that recording is occurring as desired through monitoring of the LEDs.

Slide power cable from battery pack through slit in foam.

Slide battery pack into housing and push foam down on top of battery pack. The foam will keep the battery pack from moving in the housing and producing noise.

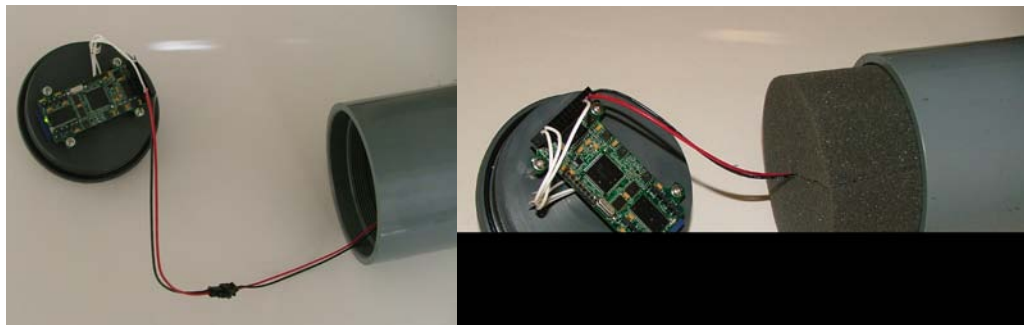

Step 5. Close Housing

Place lid on housing.

Rotate **COUNTER-CLOCKWISE (LEFT) 3 FULL TURNS** so the power cord is not coiled when the lid is closed.

Rotate lid clockwise to seal. Hand tighten until the lid is fully seated. Be careful when screwing lid not to cross-thread the lid and housing threads.

Step 6. Attach hydrophone. Attach hydrophone to the top of the housing. The hydrophone has one silver guide pin to insure proper alignment. Align hydrophone and then press straight down to insert it. Once hydrophone is seated, hand-turn retaining collar on hydrophone onto the bulkhead connector.



DSG Deployment and Maintenance

Deployment Attachments

The DSG has two bands milled on the side which can be used as attachment points for hose clamps. If you are attaching the DSG to a subsurface line you may wish to put a third hose clamp close to the top to prevent the line from banging against the housing and hydrophone. There is no band here because the housing is thinner at the top.

Use 316 Stainless Steel hose clamps.
Be sure not to overtighten hose clamps on housing.

Buoyancy and Batteries

The DSG housing will be positively buoyant if not all of the battery packs are used.

Lid Removal

Be sure to fully dry the housing before removing the lid. A strap wrench may be used to initially begin to unscrew the lid. The DSG has been coated with an acrylic conformal coating. If it is splashed with water, dry immediately. If it is immersed in water, remove it as soon as possible and immerse in alcohol.





Cold-water Deployment

If you are deploying the DSG in deep, cold water, you should place dessicant packets in the housing to prevent condensation on the electronics.

Batteries do not last as long in very cold water. Thus, you should use 50% more battery packs than suggested by DSGschedule.

BD1 Bandpass Filter Daughterboard

The BD1 Band-pass filter daughterboard is an optional accessory to the DSG that is used as an anti-aliasing filter and to provide additional gain and/or high-pass filter.

There are two filter stages on the BD1:

1. High-pass filter with gain. The corner frequency and gain of this filter are fixed at the factory. The high-pass filter is a 2-pole filter (i.e. fall off 12-dB/octave). The high-pass filter with gain may be switched on or off. The ON position is when the switch is to the right (labeled HPon).
2. Low-pass filter. The corner frequency of the low-pass filter is set by a series of dip-switches and can be varied between 1.0 kHz and 53.0 kHz. The low-pass filter is 10-pole (i.e. 60 dB per octave). The low-pass filter is always on.

Setting the low-pass corner frequency

Two (and only two) switches should be switched on to control the low-pass corner frequency. The switches labeled 'A' 'B' and 'C' are used to set a frequency range. The switches labeled '1-7' are used to set the specific frequency. These should be switched on prior to powering on the unit.

Table of low-pass filter values. Units are in kHz.

	A	B	C
1	53.3	13.3	3.33
2	45.7	11.4	2.85
3	36.8	9.2	2.30
4	29.0	7.2	1.81
5	23.4	5.8	1.46
6	18.8	4.7	1.18
7	16.0	4.0	1.00

Low-Pass Example: To set the corner frequency of the low-pass filter to 9.2 kHz, switches B and 3 should be switched ON (to the right). All other switches should be switched OFF (to the left).

The switches labeled 'clk' (clock) are not yet enabled. In the future they will allow the DSG to control the low-pass corner frequency.

Note that to use the DSG with the BD1 requires a bypass of an input capacitor on the DSG. If you purchased the BD1 with the DSG, this change will have already been made.



HTI Hydrophone Specifications

If you purchased a complete DSG System, you will have received a hydrophone manufactured by High-Tech Inc. Included with this will be a copy of the calibration of the hydrophone (located at the back of this manual).

DSG Specifications

Maximum Input Voltage: ± 0.1 V

A/D Resolution: 16-bit

Maximum Sample Rate: 80,000 Hz continuous

400,000 Hz in 1 s blocks (or continuous with stutter
record on 20% or lower duty cycle)

Low-Pass Filter: The standard DSG has a 40 kHz 2-pole low-pass filter on the hydrophone input.

Data Storage: SD or SDHC flash cards.

Power: 3.3-30.0 V

~100 mA running

~2 mA sleeping

Calibration: 10x gain on input (thus a 0.1 V signal is scaled to 32,767). Note that if the DSG is used with the BD1 there may be additional gain.

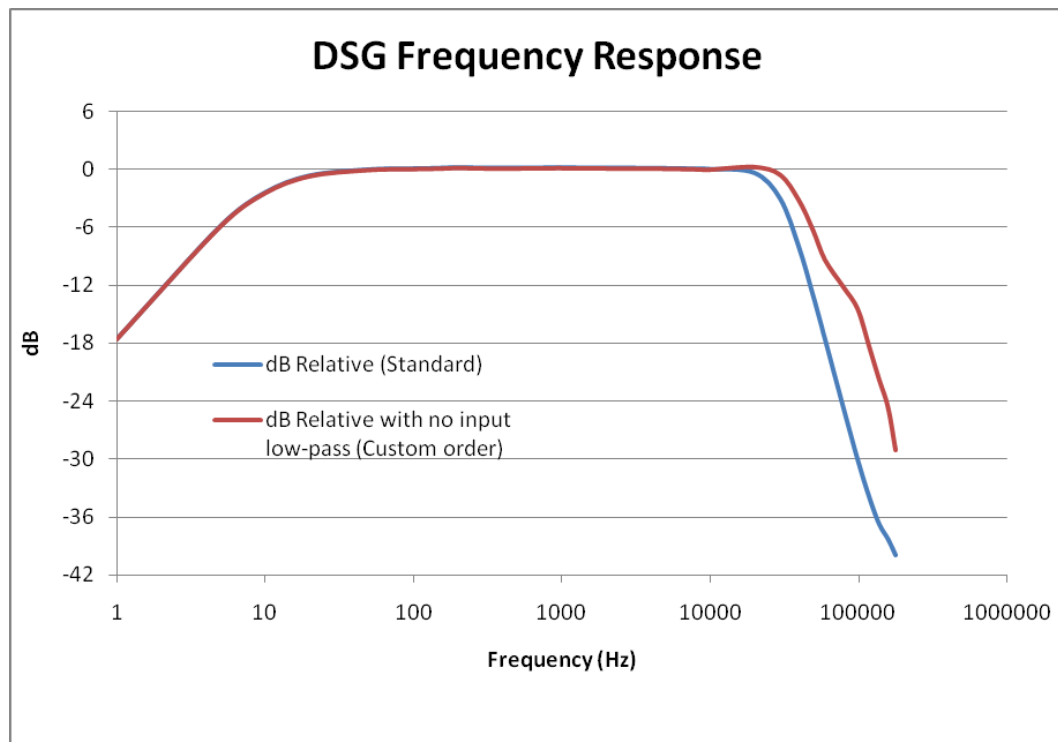



Freq (Hz)	dB Relative (Standard)	dB Relative with no input low-pass (Custom order)
1	-17.6	-17.6
5	-5.9	-5.9
10	-2.4	-2.4
20	-0.7	-0.7
50	0.0	0.0
100	0.1	0.1
150	0.1	0.1
200	0.2	0.2
300	0.1	0.1
400	0.1	0.1
500	0.1	0.1
1000	0.2	0.2
2000	0.1	0.1
4000	0.1	0.1
8000	0.0	0.0
10000	0.0	0.0
20000	-0.4	0.3
30000	-3.1	-0.5
40000	-8.0	-3.2
50000	-13.1	-6.3
60000	-17.5	-9.3
80000	-24.7	-12.2
100000	-30.1	-14.5
120000	-34.0	-18.5
140000	-36.8	-21.9
160000	-38.3	-24.7
180000	-39.9	-29.1

DSG Board Pinouts

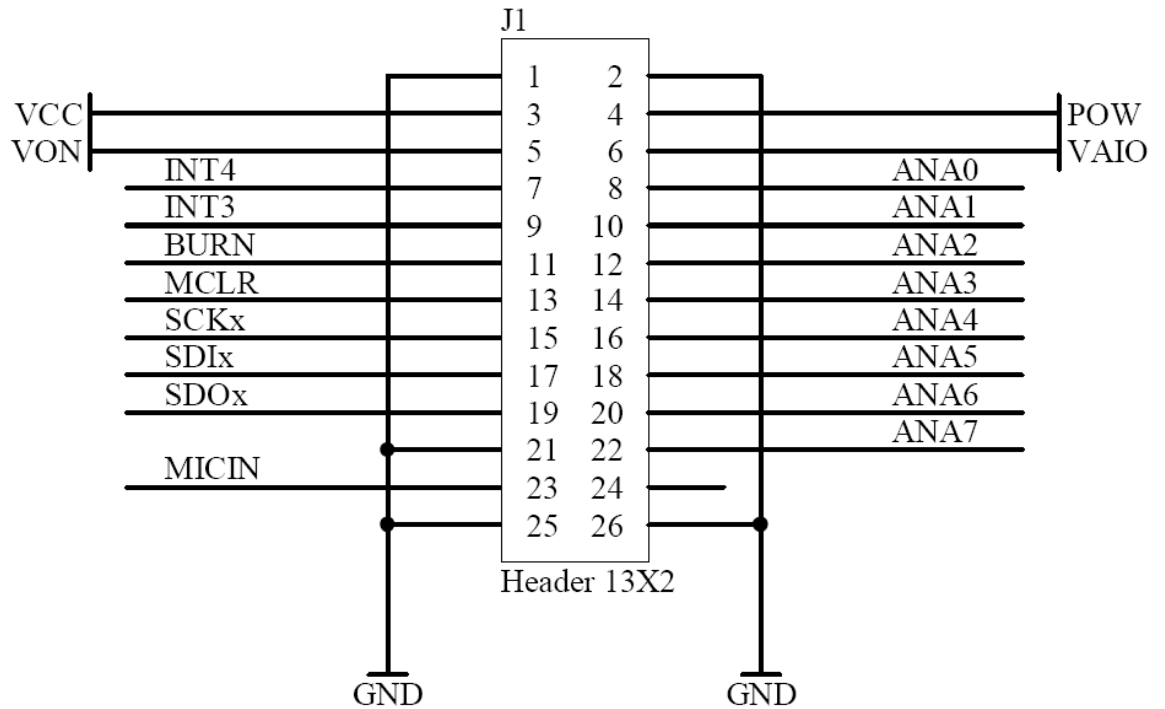

Orientation: Pin 1 has a square solder pad on the DSG board.

POW: Input power. 3.7 V – 30 V. Voltage regulator is National LP2951.

VAIO: 3.3 V regulated output. Turned off when sleeping.

VON: 3.3 V regulated output. Always on.

MICIN: Signal Input. $\pm 0.1V$ input for microphone, hydrophone, or other signal.

ANA0-ANA7: Analog inputs on dsPIC33F. Not currently implemented in current firmware release.

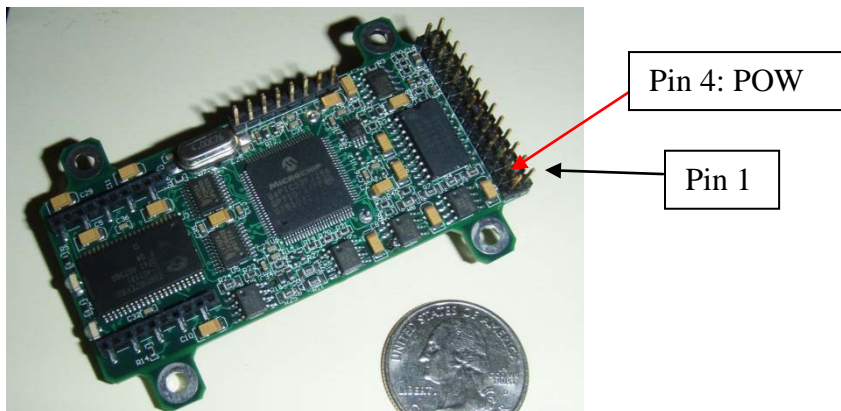



PICkit2 Microcontroller Programmer

Your DSG ships with a PICkit2 microcontroller programmer. The PICkit2 is used to update the firmware on the DSG's microcontroller as new releases are made. When you receive your DSG its flash memory is already programmed with the latest version of the firmware, so you do not need to do anything with the PICkit2. Loggerhead Instruments will notify you as new firmware releases become available.



DSG Software Revision History

DSG Software (firmware loaded on board)

- DSG v1.0** May 2008 Initial Release
- DSG v1.1** Added support for stutter recording
- DSG v1.6** Added support for continuous recording, ZIGBEE wireless.

Error trapped situations where wake up time is prior to current time.

Synchronized version number with DSGschedule.

DSGschedule

- March 15, 2009. v1.11: Corrected rounding to realizable sample rates. Also checks sample rate when Update is clicked.
- August 9, 2009. V1.12: Fixed bug in creating schedule files with multiple groups where groups did not overlap in time.
- August 30, 2009. V1.6: Added support for continuous recording. Corrected calculations for days to fill and power. Added file preview. Continuous recording required upgrading of DSG firmware to v1.6.

DSG2wav

- March 15, 2009. v1.1: Fixed rounding error in calculating sample rate. Was a problem for high sample rates (e.g. 266 kHz). Had been calculated correctly for lower sample rates (e.g. 50 kHz). The sample period stored within the .dsg file was always correct.



DSG File Format

```
/*
    Data record file begins with DF_HEAD followed
    by 1 or more SID_SPEC headers. Then a SID_SPEC
    header with all zeros. Then the data sections begin
    with each record beginning with a SID_REC followed
    by 0 to nBytes in data.
*/
typedef struct
{
    BYTE  sec;
    BYTE  min;
    BYTE  hour;
    BYTE  day;
    BYTE  mday;
    BYTE  month;
    BYTE  year;
    BYTE  NU;
}TIME_HEAD;

typedef struct
{
    ULONG Version;
    ULONG UserID;
    TIME_HEAD RecStartTime;
}DF_HEAD;

// DM added RECPTS and RECINT
typedef struct
{
    char  SID[4];
    ULONG nBytes; // Size in bytes of this record (excluding
header)
    ULONG NumChan; // Number of expected channels in store
    ULONG StoreType; // Storage Type
    ULONG CircType; // Circuit type
    ULONG DForm; // Data Format
    ULONG SP256; // Sample period (us) x 256
    ULONG RECPTS; // rec points =0 for continuous;
                otherwise stutter
    ULONG RECINT; // interval between rec pts;
}SID_SPEC;

typedef struct
{
    BYTE  nSID; // This is record I/D
    BYTE  Chan; // Channel
    UINT64 TS256; // Timestamp in usecs * 256 since block record
                started
}SID_REC;
```



```
// These constants from TDT OpenEx headers
#define EVTYPE_STRON      0x00000101
#define EVTYPE_STROFF    0x00000102
#define EVTYPE_SCALER    0x00000201
#define EVTYPE_STREAM    0x000008101
#define EVTYPE_SNIP      0x000008201
#define EVTYPE_MARK      0x000008801
#define EVTYPE_HASDATA   0x000008000

#define DFORM_FLOAT      0
#define DFORM_LONG       1
#define DFORM_SHORT      2
#define DFORM_BYTE       3
#define DFORM_DOUBLE     4
#define DFORM_QWORD      5
```